

We live our values.

Excellence • Passion • Integrity • Responsibility • GEA-versity

GEA Group is a global engineering company with multi-billion euro sales and operations in more than 50 countries. Founded in 1881, the company is one of the largest providers of innovative equipment and process technology. GEA Group is listed in the STOXX® Europe 600 Index.



GEA Aseptomag Valve Technology

Our contribution for your product and process safety

GEA Mechanical Equipment

GEA Aseptomag AG

Industrie Neuhof 28, CH-3422 Kirchberg
Phone +41(0)34 426 29 29, Fax +41(0)34 426 29 28
sales.aseptomag@gea.com, www.gea.com

2121.50002e - 10/2012

Aseptic single-seat valve technology

2-12

Aseptic double-seat valve technology

14-16

Aseptic sampling valves, sampling systems

18-19

Hygienic double-seat valve technology

20-22

Simple hygienic valves

24-28

Valve accessories

30-32

Aseptic shut-off valve AV / AVBS

Aseptic change-over valve UV

Functionality

Aseptic shut-off valves are used for the monitored control of fluids in aseptic processing plants. A welded stainless steel folding bellow is used to hermetically seal the valve spindle from outside contamination. This special design and the durable valve seat seal made of Tefasep® enables optimum process security. Aseptic change-over (divert) valves have similar design features and are used for the monitored shut-off and change-over of branched pipelines.

Use

- Valves are designed for use in the food, dairy and beverage, pharmaceutical, chemical, and cosmetics industries
- Used as a safe, reliable, and robust flow control device in aseptic process and production plants
- The modular design allows integration into diverse process applications
- Operating temperatures up to +150°C (+302°F), optionally increased up to +240°C (+464°F)
- CIP (Cleaning-In-Place) and SIP (Sterilizing-In-Place) capable, up to +160°C (+320°F)
- Suitable for applications with caustic / toxic products

Design Characteristics

- Modular design, consisting of the three main components: housing, internal assembly, and actuator
- The actuator and internal assembly are connected to the housing with a three-piece clamp
- Low-maintenance, service-friendly, and hygienic design
- All product contact surfaces are made of AISI 316L stainless steel (materials certificate available upon request) with a surface finish of 0.8 µm Ra that meets all common hygienic standards
- Complete actuator made of stainless steel
- Customer-specific materials and surface finishes available upon request
- Valve connections can be provided with aseptic flanges, screw connections, or clamps

Valve Housing

Housings for shut-off valves are available in standard or bottom-seat variants with two or three port connections each. A change-over valve contains two housings. The lower housing is available with two or three port connections and the upper housing with one or two port connections. The valves are produced with standard butt-weld connections by default.

Internal Assembly

The internal assembly is available with a shrunk-on or screwed-on valve seat seal. In addition to the standard sealing material Tefasep®, other material options (PTFE, EPDM, Viton etc.) are available.

Actuator

The standard version of the pneumatic actuator is designed as spring-closing / air-opening (NC). Other available options include: air-closing / spring-opening (NO), air-closing / air-opening (LL), or with additional venting function (AZ). In addition, both valve types are available with a manual actuator (HK).

Dimensions of the pipe connections (acc. to DIN 11866)

DN	15	25	40	50	65	80	100	125	150
DIN 11866 A (DIN 11850)									
Dim. Ø x s (mm)	19x1.5	29x1.5	41x1.5	53x1.5	70x2	85x2	104x2	129x2	154x2
DIN 11866 B (ISO)									
Dim. Ø x s (mm)	21.3x1.6	33.7x2	48.3x2	60.3x2	76.1x2	88.9x2.3	114.3x2.3	139.7x2.6	168.3x2.6
	¾"	1"	1½"	2"	2½"	3"	4"		6"
DIN 11866 C (OD)									
Dim. Ø x s (mm)	19.05x1.65	25.4x1.65	38.1x1.65	50.8x1.65	63.5x1.65	76.2x1.65	101.6x2.11		152.4x2.77
Dim. Ø x s (inch)	0.75x0.065	1.0x0.065	1.5x0.065	2.0x0.065	2.5x0.065	3.0x0.065	4.0x0.083		6.0x0.11

Dimensions of the aseptic shut-off valve AV

DN	15	25	40	50	65	80	100	125	150
D1	70	86	86	106	106	144	190	267	267
L1	243	273	288	367	367	444	372.5	600	600
L2	325	350	385	505	505	555	520	795	795
L3	40	60	75	90	90	100	135	170	170
L4	29.5	38.5	44.5	54.5	63	75.5	90	105	118.5

Other nominal diameters available upon request

Dimensions of the aseptic bottom-seat valve AVBS

DN	15	25	40	50	65	80	100	125
D1	70	86	86	106	106	144	190	267
D2	64	75	75	185	185	220	250	340
L1	237.5	270.5	294.5	371.5	371.5	448.5	394	620
L2	330	370	390	490	490	605	585	880
L3	40	60	75	90	100	130	135	170
L4	51	60.7	78.45	91.25	82.5	100	116	180

Other nominal diameters and bottom-seat versions available upon request

Dimensions of the aseptic change-over valve UV

DN	15	25	40	50	65	80	100
D1	70	86	86	106	106	144	190
L1	329.5	353.5	377	472	472	569	512
L2	420	480	500	610	610	730	670
L3	40	60	75	90	90	100	135
L4	29.5	38.5	44.5	54.5	63	75.5	90
L5	68.5	74.5	89	107	107	125	139.5

Other nominal diameters available upon request

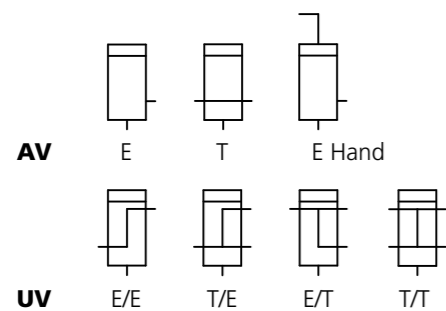
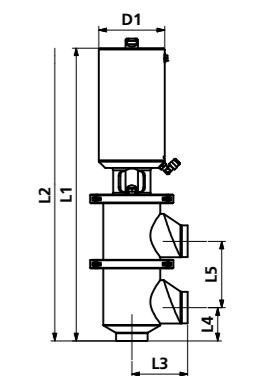
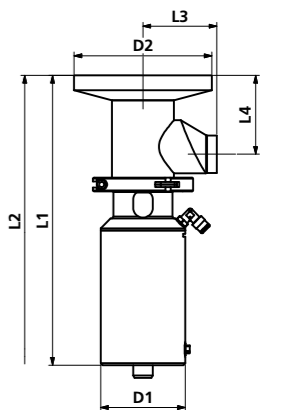
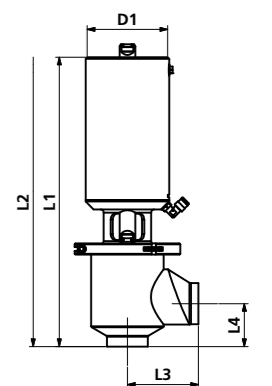
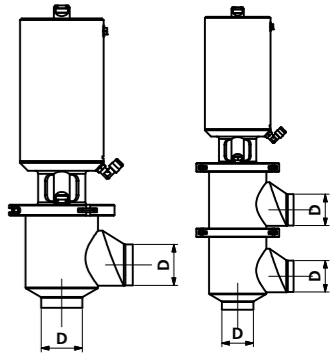

Aseptic shut-off valve with manual actuator



Aseptic shut-off valve with pneumatic actuator



Aseptic bottom-seat valve with pneumatic actuator (welding flange)



Aseptic change-over valve with pneumatic actuator



Aseptic filling valve AF

Functionality

Aseptic filling valves are used for the monitored opening and closing of pipelines in aseptic processing plants. A welded stainless steel folding bellow is used to hermetically seal the valve spindle from outside contamination. This special design and the durable valve seat seal made of Tefasep® enables optimum process security. Due to their extended bellow design, aseptic filling valves are ideal for plants with high valve stroke frequencies, such as bottling plants.

Use

- Valves are designed for use in the food, dairy and beverage, pharmaceutical, chemical, and cosmetics industries
- Used as a safe, reliable, and robust dosing device at very high valve stroke frequencies in aseptic process and production plants
- The modular valve design allows integration into diverse process applications
- Operating temperatures up to +150°C (+302°F), optionally increased up to +240°C (+464°F)
- CIP (Cleaning-In-Place) and SIP (Sterilizing-In-Place) capable, up to +160°C (+320°F)
- Suitable for applications with caustic or toxic products

Design Characteristics

- Modular design, consisting of the three main components: housing, internal assembly, and actuator
- The actuator and internal assembly are connected to the housing with a three-piece clamp
- Low-maintenance, service-friendly, and hygienic design
- All product contact surfaces are made of AISI 316L stainless steel (materials certificate available upon request) with a surface finish of 0.8 µm Ra that meets all common hygienic standards
- Complete actuator made of stainless steel
- Customer-specific materials and surface finishes available upon request
- Valve connections can be provided with aseptic flanges, screw connections, or clamps

Valve Housing

The housing is available as a bottom-seat variant with either two or three port connections. The valves are produced with standard butt-weld connections by default.

Internal Assembly

The internal assembly is available with a shrunk-on or screwed-on valve seat seal. In addition to the standard sealing material Tefasep®, other material options (PTFE, EPDM, Viton etc.) are available.

Actuator

The standard version of the pneumatic actuator is designed as spring-closing / air-opening (NC). Other designs are air-closing / spring-opening (NO) and air-closing / air-opening (LL).

Dimensions of the pipe connections (acc. to DIN 11866)

DIN 11866 A (DIN 11850)					
Dim. Ø x s (mm)	29x1.5	41x1.5	53x1.5	70x2	85x2
DIN 11866 B (ISO)					
Dim. Ø x s (mm)	33.7x2	48.3x2	60.3x2	76.1x2	88.9x2.3
	1"	1½"	2"	2½"	3"
DIN 11866 C (OD)					
Dim. Ø x s (mm)	25.4x1.65	38.1x1.65	50.8x1.65	63.5x1.65	76.2x1.65
Dim. Ø x s (inch)	1.0x0.065	1.5x0.065	2.0x0.065	2.5x0.065	3.0x0.065

Dimensions of the aseptic filling valve AF

DN	25	40	50	65	80
D1	86	86	106	106	144
L1	303	351.5	461.5	461.5	523
L2	397	495	648	648	735
L3	60	60	90	90	100
L4	95.1	128.5	181	172.5	174.5

Other nominal diameters available upon request

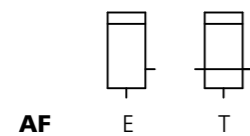
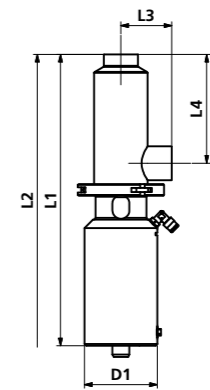
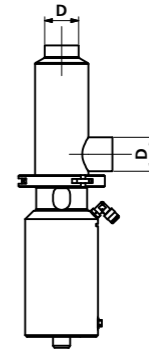

Aseptic filling valve with pneumatic actuator

Aseptic control valve RV

Functionality

Aseptic control valves are used for the exact setting and control of parameters such as flow, pressure, temperature, or filling level in aseptic processing plants. An electro-pneumatic position controller enables the precise positioning of the valve stem by controlling the pneumatic actuator. A welded stainless steel folding bellow is used to hermetically seal the valve spindle from outside contamination. This special design and the durable valve seat seal made of Tefasep® enables optimum process security.

Use

- Valves are designed for use in the food, dairy and beverage, pharmaceutical, chemical, and cosmetics industries
- Used as a safe, reliable, and robust flow control device in aseptic production and bottling plants
- The modular design allows integration into diverse process applications
- Operating temperatures up to +150°C (+302°F), optionally increased up to +240°C (+464°F)
- CIP (Cleaning-In-Place) and SIP (Sterilizing-In-Place) capable, up to +160°C (+320°F)
- Suitable for applications with caustic or toxic products

Design Characteristics

- Modular design, consisting of the three main components: housing, internal assembly, and actuator
- The actuator and internal assembly are connected to the housing with a three-piece clamp
- Low-maintenance, service-friendly, and hygienic design
- All product contact surfaces are made of AISI 316L stainless steel (materials certificate available upon request) with a surface finish of 0.8 µm Ra that meets all common hygienic standards
- Complete actuator made of stainless steel
- Customer-specific materials and surface finishes available upon request
- Valve connections can be provided with aseptic flanges, screw connections, or clamps
- Various valve control options available (see page 7)
- All valve sizes are available in various KVS values

Valve Housing

The housing is available with either two or three port connections. The valves are produced with standard butt-weld connections by default.

Internal Assembly

The internal assembly is available with a shrunk-on or screwed-on valve seat seal. In addition to the standard sealing material Tefasep®, other material options (PTFE, EPDM, Viton etc.) are available. The control cone is available in either an equal-percentage or linear design.

Actuator

The standard version of the pneumatic actuator is designed as spring-closing / air-opening (NC). Alternatively, an air-closing / spring-opening (NO) option is available.

Dimensions of the pipe connections (acc. to DIN 11866)

DN	15	25	40	50	65	80	100
DIN 11866 A (DIN 11850)							
Dim. Ø x s (mm)	19x1.5	29x1.5	41x1.5	53x1.5	70x2	85x2	104x2
DIN 11866 B (ISO)							
Dim. Ø x s (mm)	21.3x1.6	33.7x2	48.3x2	60.3x2	76.1x2	88.9x2.3	114.3x2.3
	¾"	1"	1½"	2"	2½"	3"	4"
DIN 11866 C (OD)							
Dim. Ø x s (mm)	19.05x1.65	25.4x1.65	38.1x1.65	50.8x1.65	63.5x1.65	76.2x1.65	101.6x2.11
Dim. Ø x s (inch)	0.75x0.065	1.0x0.065	1.5x0.065	2.0x0.065	2.5x0.065	3.0x0.065	4.0x0.083

Dimensions of the aseptic control valve RV

DN	15	25	40	50	65	80	100
D1	70	86	86	106	106	144	190
L1	243	273	295.5	367	367	444	372.5
L2	340	360	420	530	530	610	500
L3	40	60	75	90	90	100	135
L4	29.5	38.5	44.5	54.5	63	75.5	90

Other nominal diameters available upon request

Dimensions of the position controller

DN	15	25	40	50	65	80	100
D1	91	91	91	91	91	91	91
L1	114	114	114	114	114	114	114
L2	171	171	171	171	171	171	171
L3	82	82	82	82	82	82	82
L4	111	111	111	111	111	111	111

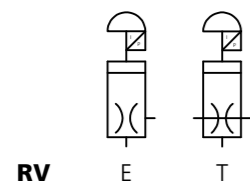
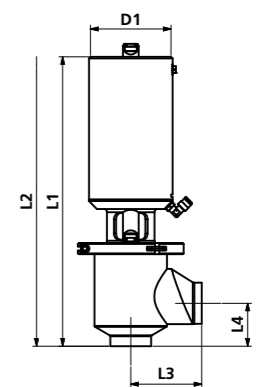
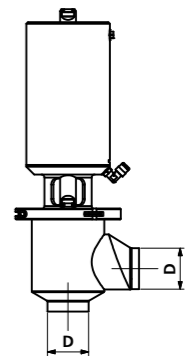

RV

E

T

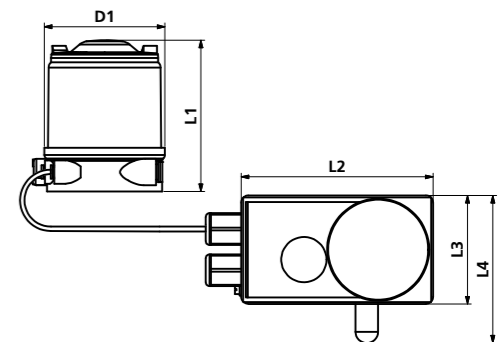
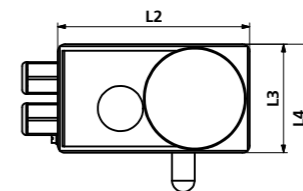
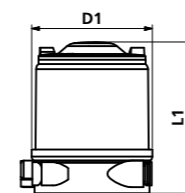

Closed Centralized Feedback System (GRZ)

Maximum hygienic option due to the centralized enclosed structure (without displacement lever, etc.). The position controller is mounted to the valve securely using a mounting kit.

Open Centralized Feedback System (ORZ)

Several open feedback systems with various functions are available. These enable the adaptation of the position controller to meet diverse customer requirements. The system is mounted to the valve using a special Aseptomag flange similar to NAMUR-mounting with a displacement lever.

Closed Decentralized Feedback System (GRD)

The position controller is connected to the distance measurement system on the valve via a cable and can therefore be placed anywhere. Decentralized feedback systems thus permit an array of design options in process-engineering plants.

Aseptic back-pressure valve GD

Functionality

Aseptic back-pressure valves are used to regulate a pre-defined pressure in aseptic processing plants (constant-pressure valve.) The desired product pressure is reached by supplying compressed air to the pneumatic actuator. A welded stainless steel folding bellow is used to hermetically seal the valve spindle from outside contamination. This special design and the durable valve seat seal made of Tefasep® enables optimum process security. Back-pressure valves are commonly used in pasteurization and sterilization plants.

Use

- Valves are designed for use in the food, dairy and beverage, pharmaceutical, chemical, and cosmetics industries
- Used as a safe, reliable, and robust flow control device in aseptic production and bottling plants
- The modular valve design allows integration into diverse process applications
- Operating temperatures up to +150°C (+302°F), optionally increased up to +240°C (+464°F)
- CIP (Cleaning-In-Place) and SIP (Sterilizing-In-Place) capable, up to +160°C (+320°F)
- Suitable for applications with caustic or toxic products

Design Characteristics

- Modular design, consisting of the three main components: housing, internal assembly, and actuator
- The actuator and internal assembly are connected to the housing with a three-piece clamp
- Low-maintenance, service-friendly, and hygienic design
- All product contact surfaces are made of AISI 316L stainless steel (materials certificate available upon request) with a surface finish of 0.8 µm Ra that meets all common hygienic standards
- Complete actuator made of stainless steel
- Customer-specific materials and surface finishes available upon request
- Valve connections can be provided with aseptic flanges, screw connections, or clamps
- The valve is designed for a standard back-pressure of 6 bar (87 psi) by default. Available in all nominal diameters
- Designs for other back-pressures are available

Valve Housing

The housing is available with either two or three port connections. The valves are produced with standard butt-weld connections by default.

Internal Assembly

The internal assembly is available with or without a shrunk-on or screwed-on valve seat seal. In addition to the standard sealing material Tefasep®, other materials options such as PTFE and EPDM are available.

Actuator

Aseptic back-pressures valves are equipped with an air-closing / air-opening (LL) pneumatic actuator.

Dimensions of the pipe connections (acc. to DIN 11866)

DN	15	25	40	50	65	80	100	125
DIN 11866 A (DIN 11850)								
Dim. Ø x s (mm)	19x1.5	29x1.5	41x1.5	53x1.5	70x2	85x2	104x2	129x2
DIN 11866 B (ISO)								
Dim. Ø x s (mm)	21.3x1.6	33.7x2	48.3x2	60.3x2	76.1x2	88.9x2.3	114.3x2.3	139.7x2.6
	¾"	1"	1½"	2"	2½"	3"	4"	
DIN 11866 C (OD)								
Dim. Ø x s (mm)	19.05x1.65	25.4x1.65	38.1x1.65	50.8x1.65	63.5x1.65	76.2x1.65	101.6x2.11	
Dim. Ø x s (inch)	0.75x0.065	1.0x0.065	1.5x0.065	2.0x0.065	2.5x0.065	3.0x0.065	4.0x0.083	

Dimensions of the aseptic back-pressure valve GD

DN	15	25	40	50	65	80	100	125
D1	60	60	60	60	86	86	106	144
L1	218	230	245	265	323	348	401	544.5
L2	320	350	380	410	460	530	580	840
L3	40	60	75	90	90	100	135	170
L4	29.5	38.5	44.5	54.5	63	75.5	90	106

Other nominal diameters available upon request

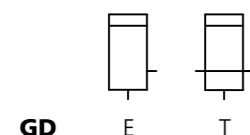
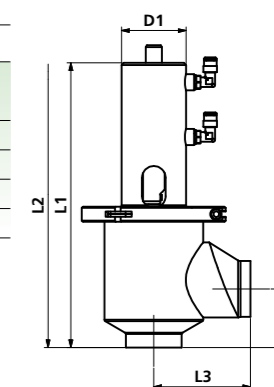
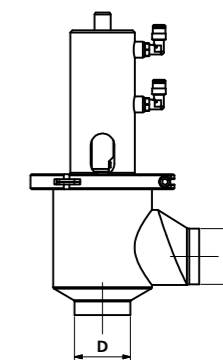

Aseptic back-pressure valve with pneumatic actuator

Aseptic mini valve AMV

Functionality

Aseptic mini valves are used for the monitored opening and closing of pipelines in aseptic processing plants. A welded stainless steel folding bellow is used to hermetically seal the valve spindle from outside contamination. This special design and the durable valve seat seal made of Tefasep® enables optimum process security. The ultra-compact and low dead-space design is suited for many diverse applications in pilot plants and miniature plant construction.

Use

- Valves are designed for use in the food, dairy and beverage, pharmaceutical, chemical, and cosmetics industries
- The valve is particularly suited for use in automated, aseptic sampling systems and pilot plants
- Operating temperatures up to +150°C (+302°F)
- SIP (Sterilizing-In-Place) capable, up to +160°C (+320°F)

Design Characteristics

- Modular design, consisting of the three main components: housing, internal assembly, and actuator
- The actuator and internal assembly are connected to the housing with a two-piece clamp
- Low-maintenance, service-friendly, and hygienic design
- All product contact surfaces are made of AISI 316L stainless steel (materials certificate available upon request) with a surface finish of 0.8 µm Ra that meets all common hygienic standards

- Complete actuator made of stainless steel
- Customer-specific materials and surface finishes available upon request

Valve Housing

The housing is available with either two or three port connections. The valves are produced with standard butt-weld connections by default, however other connection options are available upon request.

Internal Assembly

The internal assembly is equipped with a shrunk-on valve seat seal. In addition to the standard sealing material Tefasep®, a PTFE seal is also available.

Actuator

Mini valves are equipped with a spring-closing / air-opening (NC) pneumatic actuator. Optionally the actuator can be equipped with an open feedback unit M8.

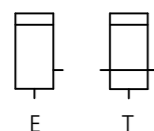
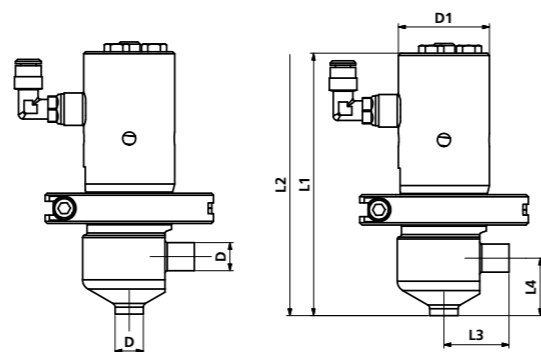

Dimensions of the pipe connections (acc. to DIN 11866)

DN	06	08	10	15	20
DIN 11866 A (DIN 11850)					
Dim. Ø x s (mm)	8x1	10x1	13x1.5	19x1.5	23x1.5
DIN 11866 B (ISO)					
Dim. Ø x s (mm)	10.2x1.6	13.5x1.6	17.2x1.6	21.3x1.6	26.9x1.6
	¼"	⅜"	½"	¾"	1"
DIN 11866 C (OD)					
Dim. Ø x s (mm)	6.35x0.89	9.53x0.89	12.7x1.65	19.05x1.65	25.4x1.65
Dim. Ø x s (inch)	0.25x0.035	0.375x0.035	0.5x0.065	0.75x0.065	1x0.065

Dimensions of the aseptic mini valve AMV

DN	06	08	10	15	20
D1	42	42	42	42	42
L1	121	121	121	121	121
L2	180	180	180	180	180
L3	40	40	40	40	40
L4	11	12	13	16	18

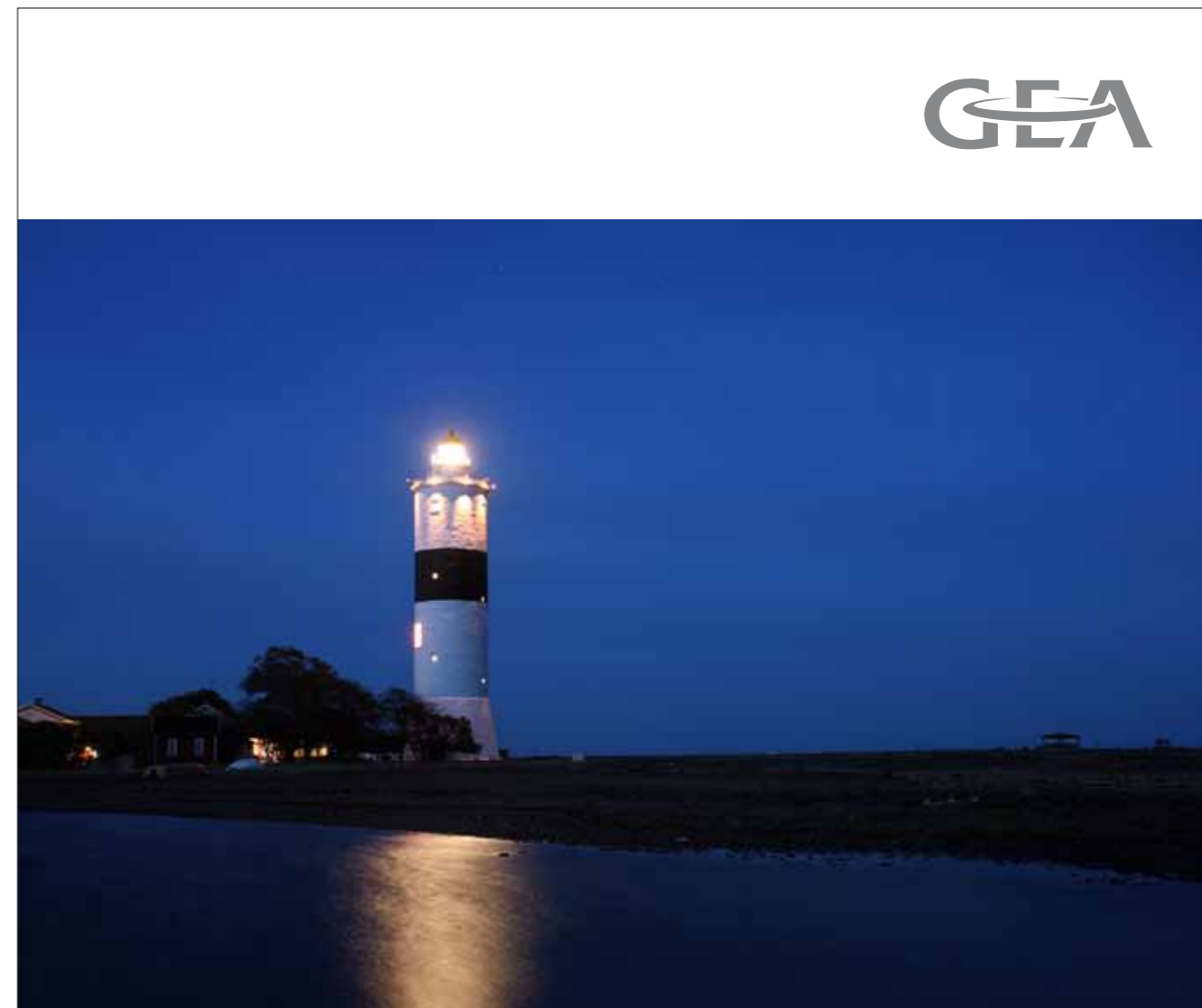

Integrity

We live our values.

Aseptic leakage valve ADV

Functionality

ADV valves are the simplest form of aseptic leakage valves. The leakage chamber is created by two seals. Through the two side valves on the leakage chamber, the intermediate chambers can be steamed, the condensate drained, and leakage problems detected. The valve seats are moved using a pneumatic hoisting mechanism.

Use

- Valves are designed for use in the food, dairy and beverage, pharmaceutical, chemical, and cosmetics industries
- Used as a safe, reliable, and robust flow control device in aseptic production and bottling plants
- The modular valve design allows integration into diverse process applications
- Operating temperatures up to +140°C (+284°F)
- CIP (cleaning in place) and SIP (sterilizing in place) capable up to +140°C (+284°F)

Design Characteristics

- Modular design, consisting of the three main

components: housing, internal assembly, and actuator

- The actuator and internal assembly are connected to the housing with a three-piece clamp
- Low-maintenance, service-friendly, and hygienic design
- All product contact surfaces are made of AISI 316L stainless steel (materials certificate available upon request) with a surface finish of 0.8 µm Ra that meets all common hygienic standards
- Complete actuator made of stainless steel
- Customer-specific materials and surface finishes available upon request
- Valve connections can be provided with aseptic flanges, screw connections, or clamps
- Integrated steam barrier

Valve Housing

The housing is available with either two, three, or four port connections. The valves are produced with standard butt-weld connections by default.

Internal Assembly

The internal assembly has two screwed-on seat seals. The top one is made of Tefasep® (alternatively PTFE) and the bottom one of EPDM.

Actuator

The standard version of the pneumatic actuator is designed as spring-closing / air-opening (NC). Alternatively, a variant with a venting cylinder (AZ) is available.

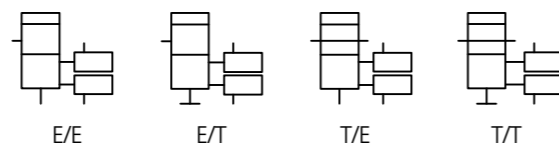
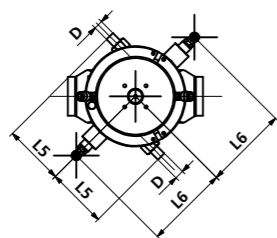
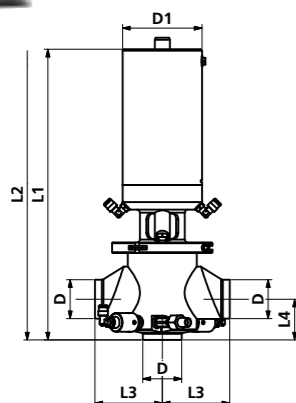

Dimensions of the pipe connections (acc. to DIN 11866)

DN	25	40	50	65	80	100
DIN 11866 A (DIN 11850)						
Abm. Ø x s (mm)	29x1.5	41x1.5	53x1.5	70x2	85x2	104x2
DIN 11866 B (ISO)						
Abm. Ø x s (mm)	33.7x2	48.3x2	60.3x2	76.1x2	88.9x2.3	114.3x2.3
	1"	1½"	2"	2½"	3"	4"
DIN 11866 C (OD)						
Abm. Ø x s (mm)	25.4x1.65	38.1x1.65	50.8x1.65	63.5x1.65	76.2x1.65	101.6x2.11
Abm. Ø x s (inch)	1.0x0.065	1.5x0.065	2.0x0.065	2.5x0.065	3.0x0.065	4.0x0.083

Dimensions of the aseptic leakage valve ADV

DN	25	40	50	65	80	100
D1	86	86	106	106	144	189.5
L1	295.5	308	388	388	444	450
L2	430	450	525	525	605	650
L3	85	85	90	90	100	135
L4	39	45	54.5	63	75.5	90
L5	81	81	81	81	87	81
L6	100	100	106	113.5	126	136

Other nominal diameters available upon request



Responsibility

We live our values.



Aseptic double-chamber valve DK / DKBS

Aseptic double-chamber valve DDK / AXV

Functionality

Aseptic double-chamber valves are flow control devices for aseptic processing plants. The integrated steam barrier (ISB) enables the safe separation of both product lines via the two seat seals. According to the complexity of the plant, the valve can be designed with one (DK), two (DDK) or three (AXV) sterile steam barriers.

The integrated function of the single-seat lifting capability permits fully automatic seat cleaning during production. The number of seals and moving parts are reduced to a minimum to provide easy maintenance and low Total Cost of Ownership. The valve enables the total separation of antagonistic media and offers you maximum process safety.

Use

- Valves are designed for use in the food, dairy and beverage, pharmaceutical, chemical, and cosmetics industries
- The modular valve design allows integration into diverse process applications
- Operating temperatures up to +150°C (+302°F), optionally increased up to +240°C (+464°F)
- CIP (Cleaning-In-Place) and SIP (Sterilizing-In-Place) capable, up to +160°C (+320°F)
- The intermediate chamber can be cleaned with condensate
- The steam and leakage valves which form the steam barrier are fully integrated into the valve body and thus enable sealing without dead spaces
- The leakage valve of the sterile chamber has a stroke of 25 mm so that particulate products may be flushed out

- The compact construction permits valve combinations with small dimensions
- A PT-100 temperature probe can be integrated into the double-chamber valve through the leakage valve for monitoring purposes

Design Characteristics

- Modular design, consisting of the three main components: housing, internal assembly, and actuator
- The actuator and internal assembly are connected to the housing with a three-piece clamp
- Low-maintenance, service-friendly, and hygienic design
- All product contact surfaces are made of AISI 316L stainless steel (materials certificate available upon request) with a surface finish of 0.8 µm Ra that meets all common hygienic standards
- Complete actuator made of stainless steel
- Customer-specific materials and surface finishes available upon request
- Valve connections can be provided with aseptic flanges, screw connections, or clamps
- Steam valve normally open by default, condensate valve normally closed. Alternate configurations are available.

Valve Housing

The housing is available as a standard or bottom-seat variant with either two, three, or four port connections. The valves are produced with standard butt-weld connections by default. Bottom-seat valve housings are available with welded flange or screwed flange connection options.

Functionality of the Double-Chamber Valve DK

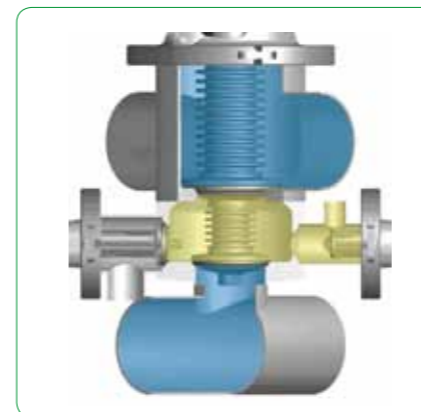

Basic position

Safe separation of media through applied steam/condensate barrier.

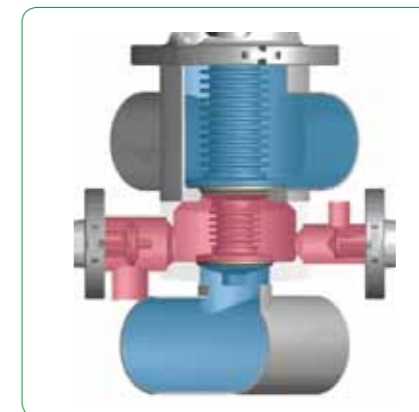

Sterilization / flushing of the leakage chamber

The steam is conducted away through the leakage valve.

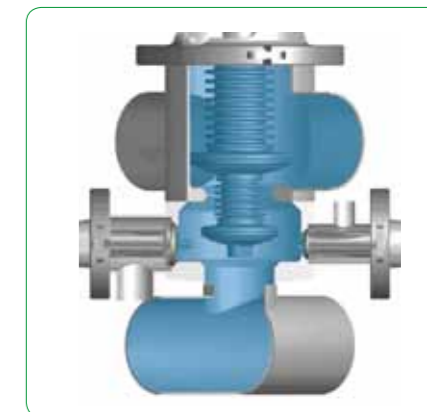

Production

The product runs through the valve.

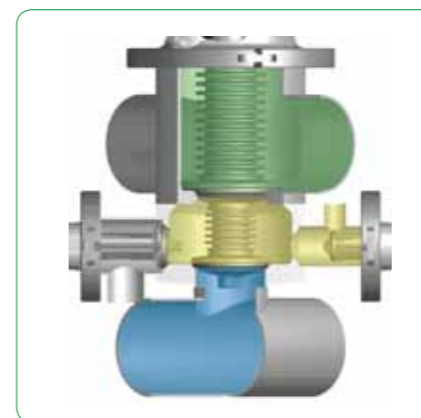

Production below – CIP above

Production (below) is secured by an active steam barrier against cleaning (above).

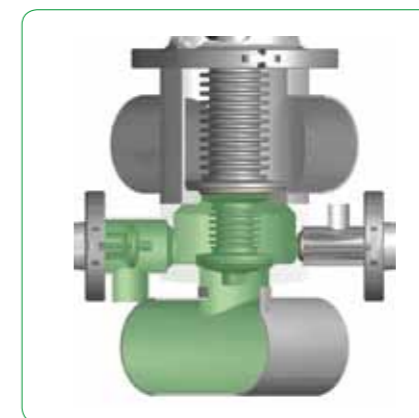

CIP / cleaning of valve seat „A“

During CIP the bottom seat is actuated to allow cleaning of the valve seat. Flushing occurs via the leakage valve. Upper seat remains sealed.

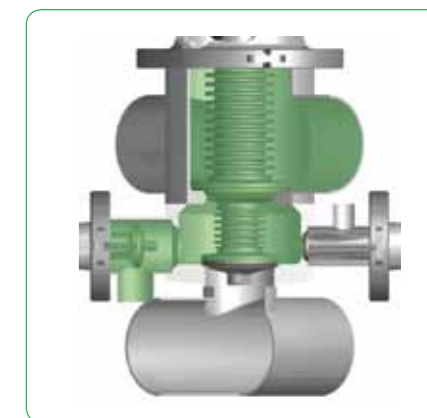

CIP / cleaning of valve seat „B“

During CIP the upper seat is actuated to allow cleaning of the valve seat. Flushing occurs via the leakage valve. Lower seat remains sealed.

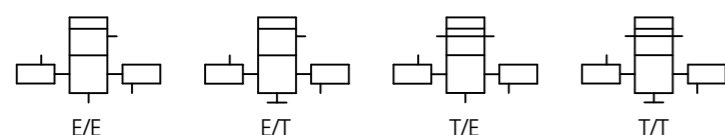

DK



Aseptic double-chamber valve with sterile barrier

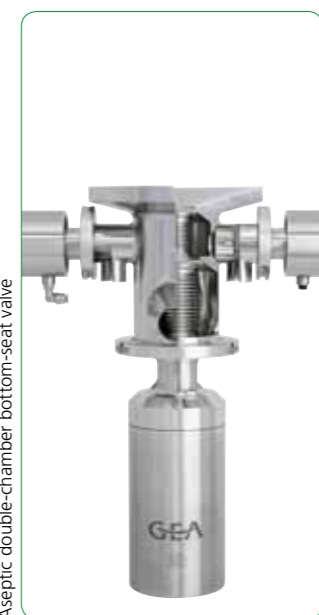

Aseptic double-chamber bottom-seat valve



Aseptic double-chamber valve type DDK with two sterile barriers



Aseptic double-chamber valve type AXV with three sterile barriers

Internal Assembly

The internal assembly is available with a shrunk-on or screwed-on valve seat seal. In addition to the standard sealant Tefasep®, other sealing materials such as PTFE, EPDM, Viton, etc., are also available. The nominal diameter of the valve is determined by the larger valve seat (upper seat seal "B" above).

Actuator

The standard version of the pneumatic actuator is designed as spring-closing / air-opening (NC). Available actuator options include: a drive without single-seat lifting (1 valve stroke), one with the seat-lifting of the bottom valve seat (seat A) and full stroke (2 valve strokes), and finally one with single-seat lifting of both valve seats (seats A+B) and valve full stroke (3 valve strokes).

- Product
- CIP
- Steam
- Condensate

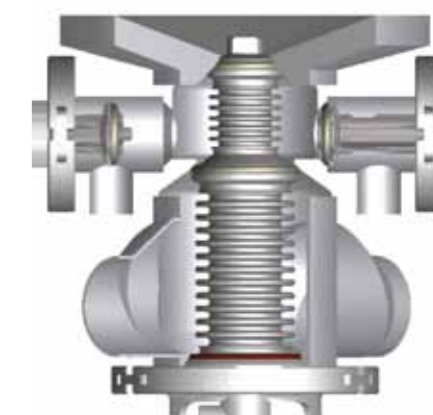

The functionality of the double-chamber bottom-seat valve DKBS is identical to that of the double-chamber valve DK.

Dimensions of the pipe connections (acc. to DIN 11866)

DN	25	40	50	65	80	100	125	150
DIN 11866 A (DIN 11850)								
Dim. Ø x s (mm)	29x1.5	41x1.5	53x1.5	70x2	85x2	104x2	129x2	154x2
DIN 11866 B (ISO)								
Dim. Ø x s (mm)	33.7x2	48.3x2	60.3x2	76.1x2	88.9x2.3	114.3x2.3	139.7x2.6	168.3x2.6
	1"	1½"	2"	2½"	3"	4"		6"
DIN 11866 C (OD)								
Dim. Ø x s (mm)	25.4x1.65	38.1x1.65	50.8x1.65	63.5x1.65	76.2x1.65	101.6x2.11		152.4x2.77
Dim. Ø x s (inch)	1.0x0.065	1.5x0.065	2.0x0.065	2.5x0.065	3.0x0.065	4.0x0.083		6.0x0.11

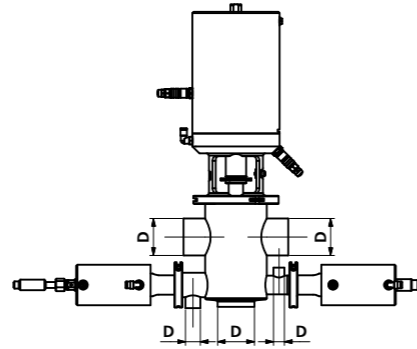

Dimensions of the aseptic double-chamber valve DK

DN	25	40	50	65	80	100	125	150
D1	92	112	112	150	192	192	220	267
L1	349.5	503.5	519	489.5	522.5	523.5	565	828
L2	490	670	750	640	700	700	820	1120
L3	74.5	90	96	105	121.5	131	145.5	189
L4	60	95	90	90	100	135	135	190
L5	52.5	67	67	74	90	101	101	131
L6	355	487	487	501	533	555	555	615

Other nominal diameters available upon request

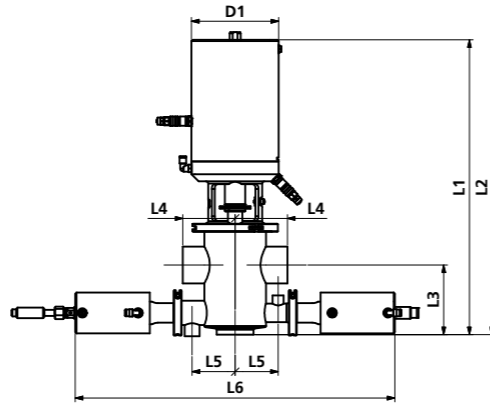

Dimensions of the aseptic double-chamber bottom-seat valve DKBS

DN	25	40	50	65	80	100	125*
D1	92	112	112	150	192	192	340
D2	140	185	185	185	220	250	267
L1	356.5	521	536.5	504	541	546.5	821
L2	486	660	680	640	740	800	1195
L3	103.4	135.5	145	135	160	165.3	223.5
L4	60	90	90	100	100	135	240
L5	52.5	67	67	74	90	101	145.5
L6	355	487	487	501	533	555	664

Other nominal diameters and bottom-seat versions available upon request

* Standard execution BSO (loose flange), further information upon request

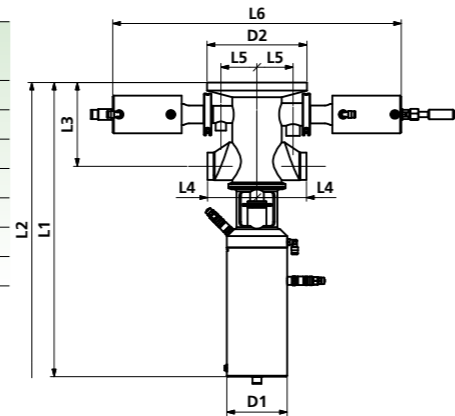

For a better overview, the spouts in all images were turned and thus do not show the standard configuration of a cross valve.



Excellence

We live our values.

Aseptic sampling valve PV Sampling system PS

Functionality

These valves are used for sampling in product lines or containers. When not actuated, the internal assembly seals the valve seat in a leakage-free manner and thus enables the seal tightness of the product line / container. Using the axial valve stroke, monitored sampling is permitted as required.

Use

- Valves are designed for use in the food, dairy and beverage, pharmaceutical, chemical, and cosmetics industries
- Valve type PV is used for aseptic and / or hygienic sampling
- Operating temperatures up to +150°C (+302°F), optionally increased up to +240°C (+464°F)
- CIP (Cleaning-In-Place) and SIP (Sterilizing-In-Place) capable, up to +160°C (+320°F)
- The modular valve design allows integration into diverse process applications

Design Characteristics

- Modular design, consisting of three main components: housing, internal assembly, and actuator (components connected via a two-piece clamp)
- Low-maintenance design
- All product contact surfaces are made of AISI 316L stainless steel (materials certificate available upon request) with a surface finish of 0.8 µm Ra that meets all common hygienic standards
- Can be designed as a welded (into pipelines and containers), screwed (onto containers), or clampable fitting
- Available in a hygienic and aseptic (metal/PTFE folding bellow) design

- The standard version of the pipe connections are designed with welded ends according to DIN 11866. Also available with an GEA Aseptomag screw connection, Keofitt, or clamp connection as desired by the customer
- The valve can be operated manually, pneumatically, or by a combination of the two
- Electric feedback via M8 initiator

Housing

The housing is available as a weld-on, screwed-on, or clampable component. In addition, all housing parts can be provided with two or three port connections (the third connection is primarily used to supply steam).

Internal Assembly

The internal assembly is available as a hygienic variant without the folding bellow and as an aseptic version with either a metal or PTFE folding bellow. In the case of the PTFE folding bellow, the valve seat seal is fully integrated. The other two versions are designed with a shrunk-on PTFE seals by default. Additional sealing materials or internal assemblies with screwed-on valve seat seals are also available upon customer request.

Actuator

When a hand lever is used for actuation, the valve stroke is initiated via a tipping movement. Like the pneumatic actuator and spring-closing / air-opening manual actuator with a pneumatic venting cylinder, this type of actuator is also part of the standard product range.

Dimensions of the pipe connections

(acc. to DIN 11866)

DN	10
DIN 11866 A (DIN 11850)	
Dim. Ø x s (mm)	13x1.5
DIN 11866 B (ISO)	
Dim. Ø x s (mm)	17.2x1.6
	½"
DIN 11866 C (OD)	
Dim. Ø x s (mm)	12.7x1.65
Dim. Ø x s (inch)	0.5x0.065

Dim. of the aseptic sampling valve PV

DN	08	15
D1	54	54
L1	145	165
L2	190	240
L3	96.6	96.6
L4	72.6	90.6

Other nominal diameters and housing versions available upon request

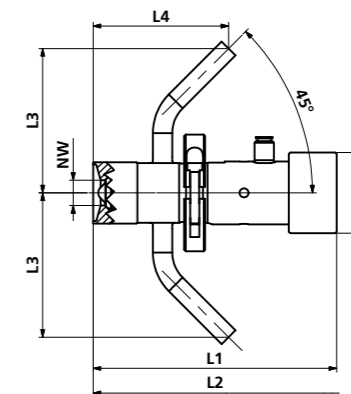
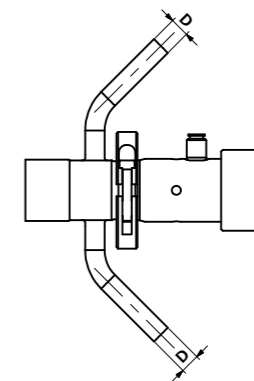

Overview of the sampling valve range



Aseptic sampling valve with metal folding bellow



Aseptic sampling valve with PTFE-bellow



Single PS with welded sampling valve



PS with integrated steam barrier



Sampling system PS

In addition to individual sampling valves, GEA Aseptomag also offers pre-assembled complete solutions for sampling. Sampling systems can be equipped for all kinds of applications and thus vary in degree of detail. Due to the modular design of the systems, it is possible to adapt these to customer requirements without great effort or expense.

Hygienic leakage valve LV

Hygienic leakage bottom-seat valve DT

Functionality

Hygienic leakage valves are mix-proof flow components for processing plants. The leakage chamber enables the safe separation of both media via two seals at all times. Any leakage that occurs at the seals is drained out through the leakage opening in a depressurized manner.

Use

- Valves are designed for use in the food, dairy and beverage, pharmaceutical, chemical, and cosmetics industries
- Used as a safe, reliable, and robust flow control device in hygienic (low-germ and highly clean) production and bottling plants
- The modular valve design allows integration into diverse process applications
- Operating temperatures up to +140°C (+284°F)
- CIP (cleaning in place) and SIP (sterilizing in place) capable up to +140°C (+284°F)

Design Characteristics

- Modular design, consisting of the three main components: housing, internal assembly, and actuator
- The actuator and internal assembly are connected to the housing with a three-piece clamp
- Low-maintenance, service-friendly, and hygienic design
- All product contact surfaces are made of AISI 316L stainless steel (materials certificate available upon request) with a surface finish of 0.8 µm Ra that meets all common hygienic standards
- Complete actuator made of stainless steel
- Customer-specific materials and surface finishes available upon request
- Valve connections can be provided with hygienic flanges, screw connections, or clamps
- All valve positions can be detected at the top of the actuator
- The low-maintenance design enables low operating and maintenance costs
- Minimum number of seals that come into contact with the product due to the use of welded stainless steel folding bellows
- Thorough cleaning and steaming of the bottom valve seat possible through seat lifting

Valve Housing

Housings for leakage valves are available with either two, three, or four port connections. Housings for leakage bottom-seat valves are available with one or two port connections. For both types, the valves are produced with standard butt-weld connections by default. In addition to the normal bottom-seat version, DT housings are also available with welded or screwed flange connections.

Internal Assembly

The standard version of the top valve seat is designed with a Tefasep® seal and the bottom seat with an EPDM seal (additional sealing materials available upon request). The internal assembly can be equipped with an optional steam connection and thus offers the possibility of a depressurized sanitation of the leakage chamber.

Actuator

The pneumatic actuator for the hygienic leakage valves LV and leakage bottom-seat valves DT is designed to be spring-closing / air-opening (NC). In the standard design, this permits the lifting of the bottom valve seat in addition to the full stroke.

Functionality of the leakage valve LV

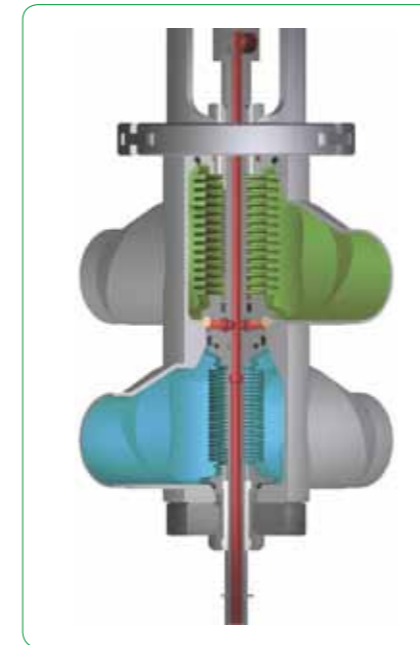

Basic position

Safe separation of two media through two valve seat seals which separate the leakage chamber from the product chamber. The supply of steam through the piston rod permits the removal of steam from the leakage chamber and increases process safety.

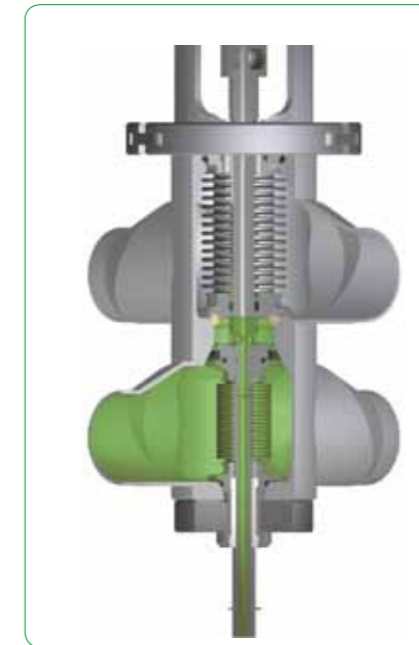

Seat lifting, bottom

The lifting of the lower valve seat permits a thorough cleaning of the valve seat and leakage chamber during the CIP process.



Intermediate position

If the full stroke of the valve is actuated, the bottom valve seat moves towards the top valve seat first. The leakage chamber is sealed with the bottom valve seat seal. Thus the actuation is accomplished without leakage.

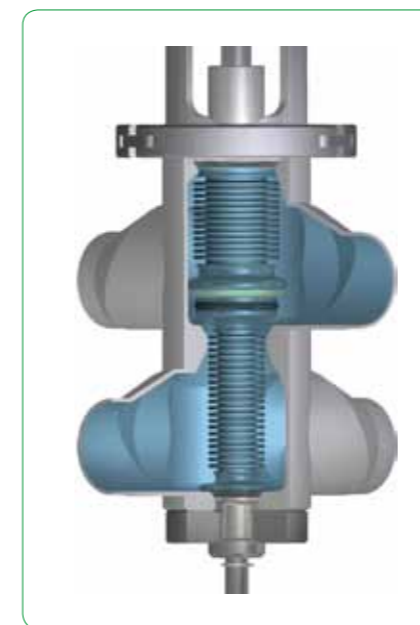

Full stroke

When the end position is reached, the safely sealed internal assembly remains there to enable a maximum product flow through the valve.

- Product
- CIP
- Steam

Leakage bottom-seat valve DT



The functionality of the leakage bottom-seat valve DT is identical to that of the leakage valve LV.

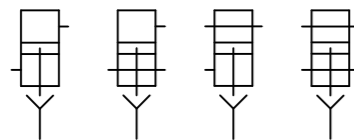

LV E/E E/T T/E T/T

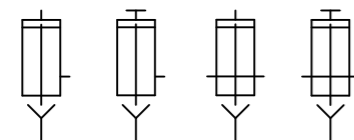

DT E/E E/T T/E T/T



Hygienic leakage valve LV with pneumatic actuator

Hygienic leakage bottom-seat valve DT with pneumatic actuator

Dimensions of the pipe connections (acc. to DIN 11866)

DN	25	40	50	65	80	100
DIN 11866 A (DIN 11850)						
Dim. Ø x s (mm)	29x1.5	41x1.5	53x1.5	70x2	85x2	104x2
DIN 11866 B (ISO)						
Dim. Ø x s (mm)	33.7x2	48.3x2	60.3x2	76.1x2	88.9x2.3	114.3x2.3
	1"	1½"	2"	2½"	3"	4"
DIN 11866 C (OD)						
Dim. Ø x s (mm)	25.4x1.65	38.1x1.65	50.8x1.65	63.5x1.65	76.2x1.65	101.6x2.11
Dim. Ø x s (inch)	1.0x0.065	1.5x0.065	2.0x0.065	2.5x0.065	3.0x0.065	4.0x0.083

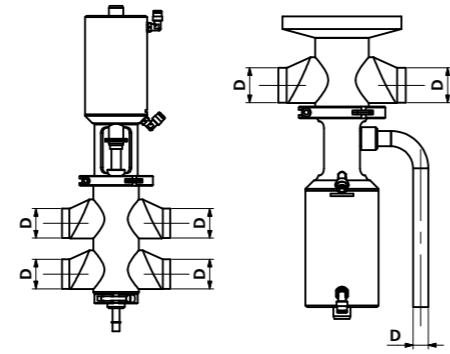

Dimensions of the hygienic leakage valve LV

DN	25	40	50	65	80	100
D1	86	86	144	144	190	190
L1	435	438	537	537	577	635
L2	650	650	790	790	830	985
L3	75	75	100	90	150	135
L4	21	27	34	42.5	50	59.5
L5	70.5	70.5	100	104	107	125.5

Other nominal diameters available upon request

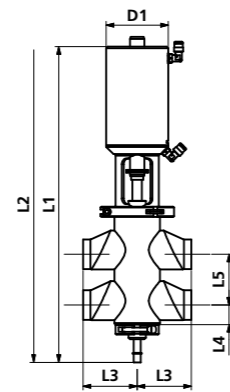

Dimensions of the hygienic leakage bottom-seat valve DT

DN	25	40	50	65	80	100
D1	86	86	144	144	190	190
D2	140	140	185	185	220	250
L1	342	342	394.5	394.5	434	466
L2	460	460	550	550	590	660
L3	75	75	100	90	150	135
L4	87	81	96	87.5	103.2	116.2

Other nominal diameters and bottom-seat versions available upon request

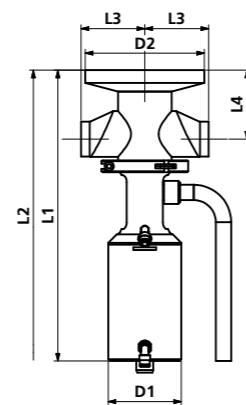

For a better overview, the top spouts in both LV images were turned by 90° and thus does not show the standard configuration of a cross valve.



Passion

We live our values.

Hygienic steam inlet valve DE

Functionality

Hygienic steam inlet valves are used for the monitored supply of steam in containers or tanks. The valve seat is closed by a pressure spring and opens as soon as the steam pressure exceeds the spring force. The optional pneumatic actuator is used to increase the closing force and to open the valve without the application of steam.

Use

- Valves are designed for use in the food, dairy and beverage, pharmaceutical, chemical, and cosmetics industries
- Used as a safe, reliable, and robust flow control device for steam in hygienic and aseptic processing plants
- Operating temperatures up to +160°C (+320°F)
- SIP (Sterilizing-In-Place) capable, up to +160°C (+320°F)
- Designed for attachment to tanks and other containers

Design Characteristics

- Modular design, consisting of the four main components: welded flange, housing, internal assembly, and actuator
- The actuator and internal assembly are connected to the housing with a three-piece clamp
- Low-maintenance, service-friendly, and hygienic design
- All product contact surfaces are made of AISI 316L stainless steel (materials certificate available upon request) with a surface finish of 0.8 µm Ra that meets all common hygienic standards
- Complete actuator made of stainless steel
- Customer-specific applications available upon request

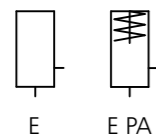

Welded flange

For both the mechanical and pneumatic versions, the welded flange is identical and fixed to the valve using four screws.

Internal Assembly

The contact force of the valve seat seal is adjusted using an adjusting nut in the case of valve type DE. In the case of valve type DE PA, adjustment takes place using compressed air in the actuator. All internal assemblies are equipped with a Tefasep® seal by default.

Actuator

Steam inlet valves DE do not have an actuator. Valve type DE PA, on the other hand, is equipped with an air-closing / air-opening pneumatic actuator (LL).

Dimensions of the pipe connections (acc. to DIN 11866)

DN	25	40
DIN 11866 A (DIN 11850)		
Dim. Ø x s (mm)	29x1.5	41x1.5
DIN 11866 B (ISO)		
Dim. Ø x s (mm)	33.7x2	48.3x2
	1"	1½"
DIN 11866 C (OD)		
Dim. Ø x s (mm)	25.4x1.65	38.1x1.65
Dim. Ø x s (inch)	1.0x0.065	1.5x0.065

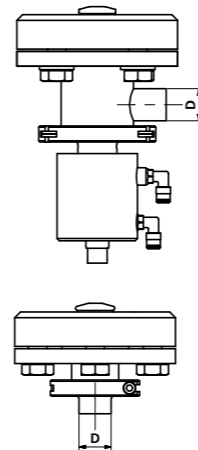

Dimensions of the steam inlet valve DE PA

DN	25	40
D1	70	70
D2	140	165
L1	197	209
L2	310	335

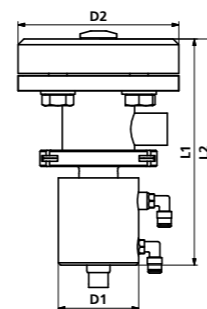

Dimensions of the steam inlet valve DE

DN	25
D1	140
L1	88.5

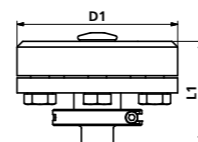

Steam inlet valve with pneumatic actuator

Steam inlet valve without pneumatic actuator

Hygienic vacuum valve VV

Functionality

Hygienic vacuum valves are used to secure lines in processing plants against impermissibly occurring vacuums (e.g. after sterilization). The valve is triggered using a pre-tensioned spring as soon as the pipe system has a certain negative pressure.

Use

- Valves are designed for use in the food, dairy and beverage, pharmaceutical, chemical, and cosmetics industries
- Used as a pressure equalization fitting in hygienic processing plants
- Operating temperatures up to +140°C (+284°F)
- The valve is designed for direct attachment to the air pipelines

Design Characteristics

- Available in nominal diameters 25–50
- Low-maintenance, service-friendly, and hygienic design
- The components of the valve body are manufactured from stainless steel AISI 316L and meet all common hygiene standards
- Customer-specific materials and surface finishes available upon request
- Standard pipeline connection with screw connection according to DIN 11851
- Upon customer request, the pipeline connection can also be designed as a welded end, with clamp connection or connections according to DIN 11864

Dimensions of connecting threaded spout (acc. to DIN 11851)

DN	25	40	50
Dim. of the thread			
Nominal diameter	Rd52x1/6	Rd65x1/6	Rd78x1/6

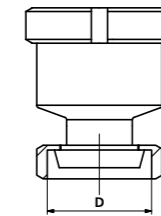

Dimensions of the vacuum valve VV

DN	25	40	50
D1	70	92	119
D2	63	78	92
L1	96.5	99.5	113.5

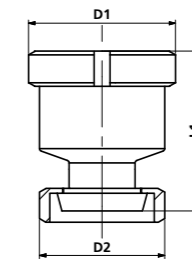

Vacuum valves DN 25-50

Hygienic non-return valve RSV

Functionality

Hygienic non-return valves prevent a return flow of media in processing plants. The spring-equipped valve in the RSV series requires only a low-to-medium pressure to open. The durable valve seat seal made of EPDM enables optimum seal integrity.

Use

- Valves are designed for use in the food, dairy and beverage, pharmaceutical, chemical, and cosmetics industries
- Suitable for both horizontal and vertical use
- Operating temperatures up to +140°C (+284°F)
- CIP (cleaning in place) and SIP (sterilizing in place) capable up to +140°C (284°F)

Design Characteristics

- Modular design, consisting of two housing halves and internal assembly
- The housing halves and internal assembly are connected with a three-piece clamp
- Low-maintenance design
- All product contact surfaces are made of AISI 316L stainless steel (materials certificate available upon request) with a surface finish of 0.8 µm Ra that meets all common hygienic standards
- Low spring force so that the valve opens at low-to-medium pressure

Housing

Both housing halves are designed with welded ends by default. Other connections can also be provided upon request.

Internal Assembly

Internal assemblies are available with one-piece or separable valve plates. In addition to the standard sealant EPDM, additional material options such as PTFE and Viton are available.

Dimensions of the pipe connections (acc. to DIN 11866)

DN	15	25	40	50	65
DIN 11866 A (DIN 11850)					
Dim. Ø x s (mm)	19x1.5	29x1.5	41x1.5	53x1.5	70x2
DIN 11866 B (ISO)					
Dim. Ø x s (mm)	21.3x1.6	33.7x2	48.3x2	60.3x2	76.1x2
	¾"	1"	1½"	2"	2½"
DIN 11866 C (OD)					
Dim. Ø x s (mm)	19.05x1.65	25.4x1.65	38.1x1.65	50.8x1.65	63.5x1.65
Dim. Ø x s (inch)	0.75x0.065	1.0x0.065	1.5x0.065	2.0x0.065	2.5x0.065

Dimensions of the non-return valve RSV

DN	15	25	40	50	65
D1	102	102	119	147	190
D2	53	53	70	90	108
L1	100	100	100	127	124

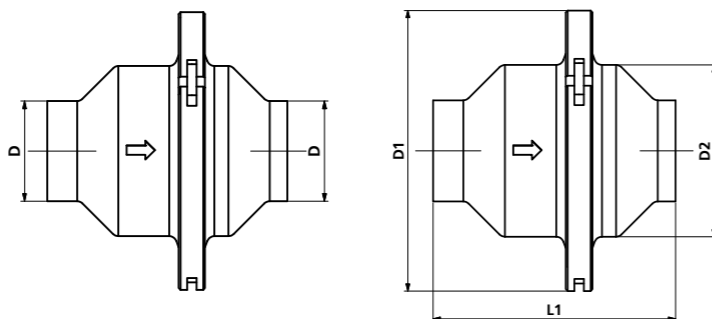

Hygienic non-return valve

Hygienic solenoid non-return valve MRV

Functionality

Hygienic solenoid non-return valves prevent a return flow of media in processing plants. The valve housing, which is equipped with a magnet, constantly pulls the special flow element into the closed position and thus prevents a return flow. For opening, type MRV requires only a low-to-medium pressure. No soluble or moving parts can be found in this non-return valve, which decisively increases operating safety. The durable valve seat seal made of EPDM enables optimum seal integrity.

Use

- Valves are designed for use in the food, dairy and beverage, pharmaceutical, chemical, and cosmetics industries
- Suitable for both horizontal and vertical use
- Operating temperatures up to +140°C (+284°F)

Design Characteristics

- Modular design, consisting of the housing and internal assembly
- All product contact surfaces are made of AISI 316L stainless steel (materials certificate available upon request) with a surface finish of 0.8 µm Ra that meets all common hygienic standards
- Low magnetic force so that the valve opens at low-to-medium pressure

Housing

The basic body of the housing is designed with welded ends on both sides by default. Optionally, the connections can also be provided with a tri-clamp or screw connection.

Internal Assembly

The valve seat seal is available in EPDM, NBR, FPM (Viton), Silicone, and FEP. Optionally, a metallically sealing internal assembly is also available.

Dimensions of the pipe connections (acc. to DIN 11866)

DN	8	10	15	25	40	50	65	80	100
DIN 11866 A (DIN 11850)									
Dim. Ø x s (mm)	10x1	13x1.5	19x1.5	29x1.5	41x1.5	53x1.5	70x2	85x2	104x2
DIN 11866 B (ISO)									
Dim. Ø x s (mm)	13.5x1.6	17.2x1.6	21.3x1.6	33.7x2	48.3x2	60.3x2	76.1x2	88.9x2.3	114.3x2.3
	¾"	½"	¾"	1"	1½"	2"	2½"	3"	4"
DIN 11866 C (OD)									
Dim. Ø x s (mm)	9.53x0.89	12.7x1.65	19.05x1.65	25.4x1.65	38.1x1.65	50.8x1.65	63.5x1.65	76.2x1.65	101.6x2.11
Dim. Ø x s (inch)	0.375x0.035	0.5x0.065	0.75x0.065	1.0x0.065	1.5x0.065	2.0x0.065	2.5x0.065	3.0x0.065	4.0x0.083

Dimensions of the solenoid non-return valve MRV

DN	8	10	15	25	40	50	65	80	100
D1	54	54	54	72	90	105	130	150	170
L1	60	60	60	80	100	110	130	140	150



Hygienic solenoid non-return valve

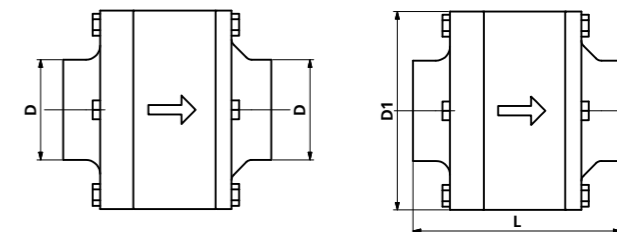

Hygienic ball valve KH

Functionality

Hygienic ball valves are rotation valves that are used for the monitored opening and closing of pipelines in processing plants. Ball valves of the type KH are simple, safe, and affordable flow control elements. They can withstand very high pressures and are designed to be low in dead space.

Use

- The valve can be used in the food and beverage industries
- Operating temperatures up to +140°C (+284°F)
- The valve is installed into straight sections of product lines
- Due to the robust ball segment, the valve can be used to block lines with high pressure loads

Design Characteristics

- Modular design, consisting of the housing, ball, seat ring, and actuator
- All product contact surfaces are made of AISI 316L stainless steel (materials certificate available upon request) with a surface finish of 0.8 µm Ra that meets all common hygienic standards
- The valve fulfills Pressure Equipment Directive 97/23/EC and is Firesafe-certified (BS 67 55) and compliant with ATEX 94/9/EC
- The seat ring is available in PTFE, PEEK, and UHMV
- The housing seal is available as PTFE or graphite
- Piggable ball valves are available upon customer request

Housing

The connecting ends of a ball valve housing can have varying designs. In addition to various welded ends, flanges with a threaded connection are also available.

Actuator

Ball valves can be equipped with a manual or pneumatic actuator.

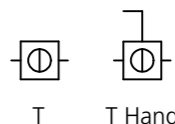

Dimensions of the pipe connections (acc. to DIN 11866)

	15	25	40	50	65	80	100
DIN 11866 A (DIN 11850)							
Dim. Ø x s (mm)	19x1.5	29x1.5	41x1.5	53x1.5	70x2	85x2	104x2
DIN 11866 B (ISO)							
Dim. Ø x s (mm)	21.3x1.6	33.7x2	48.3x2	60.3x2	76.1x2	88.9x2.3	114.3x2.3

	¾"	1"	1½"	2"	2½"	3"	4"
DIN 11866 C (OD)							
Dim. Ø x s (mm)	19.05x1.65	25.4x1.65	38.1x1.65	50.8x1.65	63.5x1.65	76.2x1.65	101.6x2.11
Dim. Ø x s (inch)	0.75x0.065	1.0x0.065	1.5x0.065	2.0x0.065	2.5x0.065	3.0x0.065	4.0x0.083

Dimensions of the hygienic ball valve KH

DN	15	25	40	50	65	80	100
D1	76	76	104	104	133	133	133
L1	268	293	334.5	360.5	474	496	526
L2	75	110	130	143	185	205	240
L3	25.5	33.5	43.5	61.5	73	86.5	100.5

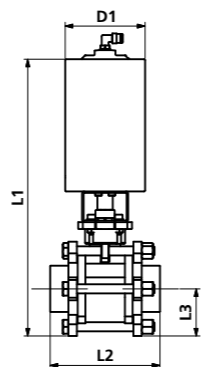
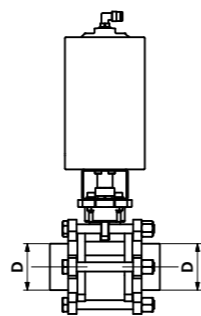

Hygienic ball valve with pneumatic actuator

Certification

In our opinion, high quality products and constantly striving for optimum hygienic design are the basic pillars for successful project development in the food industry. We place great value in fulfilling all requirements of various institutions relevant to the food industry and its certifications.



ISO 9001

Structured processes and continuous quality assurance are absolutely necessary for optimum project settlement. ISO 9001 helps us enable international standards, discover defects, and constantly develop ourselves further.



ISO 3834-2

For us, ISO 3834-2 has a particularly high value because the entire welding process is certified with this standard. For the construction of hygienic/aseptic components and processing plants, it is of great importance.



3A Standard

Since 1956, the 3A Commission has been dedicated to the development of design guidelines for components used in the food industry. We, as a leading company in the area of aseptic process technology, place great value in designing existing components and new product developments according to these guidelines.



EHEDG

The European Hygienic Engineering and Design Group deals with the topic of hygienic design. We consistently use the recommendations it has worked out in our designs. We do not merely limit ourselves to observing the guidelines and having our products checked for cleanliness, but rather we want to impart our knowledge actively to the EHEDG. For this reason, Aseptomag has been a proud member of EHEDG since 2009.



Steam barrier DS Leakage monitor LW

Functionality DS

The leakage chamber is sterilized using steam. For this purpose, steam is applied through a connection on the housing, conducted through the internal assembly in a defined way, and conducted out through the hollow axis. For leakage monitoring during production, the valve V2 is closed and condensate forms in the system. The following steam must have a 0.5 bar higher pressure than the product.

In case of leakage, the condensate thus escapes to the product chamber and the following steam increases the temperature for TIS1. Through this temperature increase, the PLC detects the leakage.

Design Characteristics

- Housing with two integrated connections
- The one connection on the housing is sealed in a leakage-free manner using blind stoppers by default
- The internal assembly has a hollow axis and a special valve cover with two lateral bore-holes
- Secured housing seals using the steam barrier

Installation

- The DS system is primarily designed for equipping new installations
- The pipe connections on the housing can be permanently fixed to the plant
- For the connection to the internal assembly, a flexible connection is required
- Suitable for upright installation
- In certain conditions may be installed in a reclined position
- Not suitable for inverted installation

Functionality LW

The leakage chamber is sterilized using steam. For this purpose, steam is applied through a connection on the intermediate flange and conducted away again through the second connection that is also on the intermediate flange. For leakage monitoring during production, the valve V2 is closed and condensate forms in the system. The following steam must have a 0.5 bar higher pressure than the product.

In case of leakage, the condensate thus escapes to the product chamber and the following steam increases the temperature for TIS1. Through this temperature increase, the PLC detects the leakage.

Design Characteristics

- Additional flange with two integrated connections
- Connection to the valve using an additional clamp
- The internal assembly has an extended valve axis
- Various monitoring media (e.g. glycerine) can be used

Installation

- The LW system is primarily designed for the retrofitting of existing installations
- The connections on the flange to a monitoring system are established with flexible lines
- Suitable for upright installation
- In certain conditions may be installed in a reclined position
- Not suitable for inverted installation

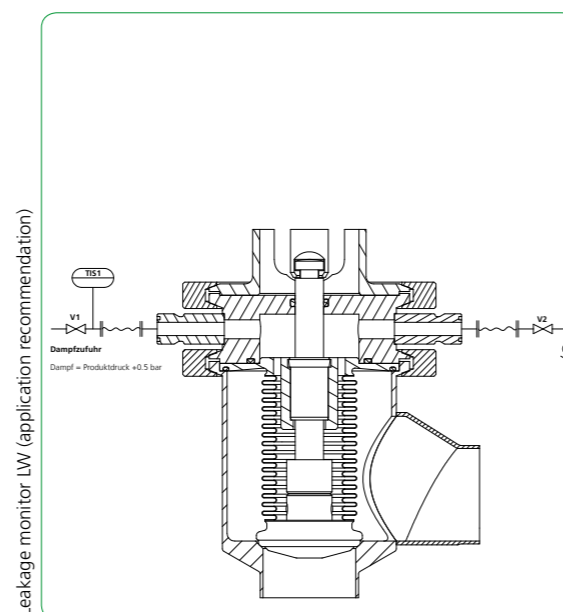
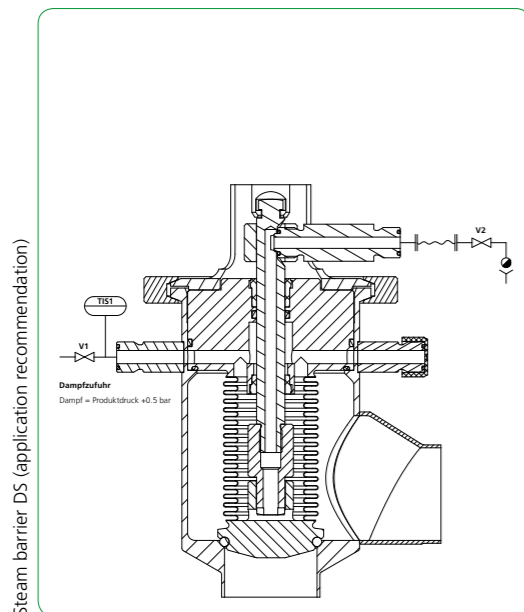

Bellow monitor BW

Functionality

A bellow monitor can be operated with both the DS and LW systems. By default, both installations require the use of blind covers for a connection on the housing / flange and the connection of a level container to the other connection. During commissioning, the container of the system is filled with pure glycerine up to a defined level. Through the actuation of the valve, the volume inside the internal assembly is displaced.

This volume is taken up in the level container and monitored with a magnetic float switch. If leakage occurs in the bellow and product penetrates the system, the level in the container rises. If leakage occurs in negative pressure conditions, the glycerine level in the level container drops. In both cases, bellow monitoring electronics trigger an alarm and sends it to the PLC.

Design Characteristics

- Visual status display in the container via LED
- Yellow LED = System OK
- Blue LED = System alarm
- Class of protection IP65
- Adjusted container size for all GEA Aseptomag valve types and nominal diameters
- The level container is sealed against the atmosphere in an air-tight manner
- Air compensation in the level container takes place via a folding bellow

Installation

- Valves that have either the DS or LW system can be retrofitted at any time
- The base plate of the bellow monitor may be mounted directly to the pneumatic actuator or between the actuator and the feedback unit
- The use of the bellow monitoring system does not preclude the use of a valve feedback unit
- The level container can be disassembled without the electronics having to be removed from the valve

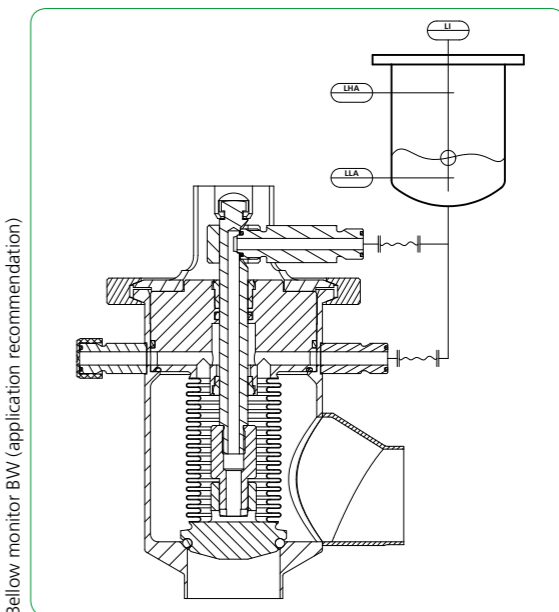

T.VIS® feedback system

Functionality

T.VIS® feedback system reduces the amount of wiring on a valve cluster. The centrally installed feedback unit enables the visualization of the valve positions using inductive proximity switches and flashing indicator on top of the control module. The integrated solenoid valves control the pneumatic actuator.

All these components are installed together with either a plug connection or bus-capable PC board and can be connected to a PLC control system.

Use

- For use in fully automated processing plants
- Designed for use and mounting on all GEA Aseptomag valve types
- Existing installed valves may be retrofitted at any time to use T.VIS® Feedback systems
- Variable equipment of the T.VIS® according to the modular design principle (e.g. interface type, number of solenoid valves etc.)
- The T.VIS Feedback system has a wide range of equipment options that allow the adaption to various processes and customer requirements

Design Characteristics

- Visual status display via flashing indicator, clearly visible from all sides
- LED display colors: green, yellow
- Optimized design for external cleaning
- Modular structure (expansion / retro-fitting at any time)
- Up to two, manually adjustable, inductive proximity switches may be internally mounted
- Up to three integrated solenoid valves
- Connection types AC, AS-Interface and DeviceNet
- Maintenance-free electronic modules
- Protection class IP66 (optional IP67)
- Optional with additional external sensor for the detection of a seat lift
- Equipment with optional NOT element to support the closing function of the actuator
- Special material with particular resistance against UV radiation and air with high fat/oil content available

Connection to GEA Aseptomag valves

	PA50-210	PA255
Reference diameter (mm)	40	50
Number of screws	4	4

Dimensions of T.VIS®

	PA50-210	PA255
D1	146	146
L1	197	197
L2	176	176

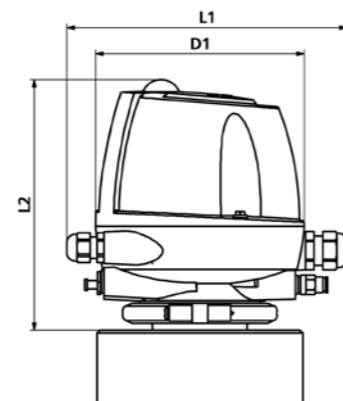

T.VIS® feedback system